

Turnkey Solutions for Radiation Protection in PET Laboratories

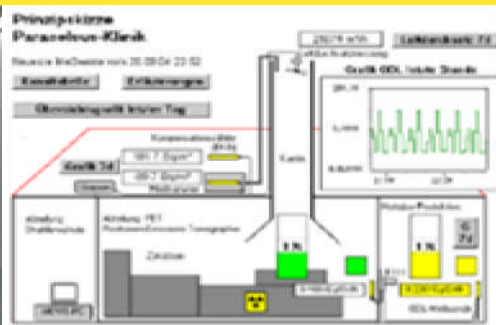
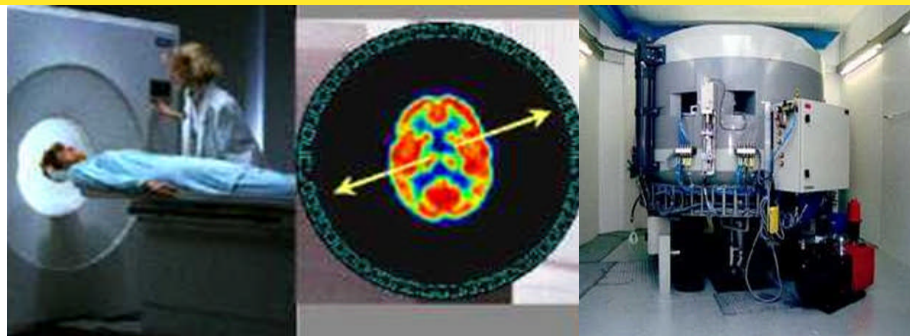

Berthold Technologies has more than 60 years experience in manufacturing radiation protection measuring systems. We provide a comprehensive range of monitoring and control systems for radiation protection in PET facilities including survey monitors, neutron monitors, installed and portable gamma dose rate, activity in room air and stack emission systems.

Continuous measurement of gamma dose rate in each room together with unique gamma insensitive positron detectors for localisation of room air activity ensures personnel are always informed of the levels of each type of radiation. Alarm levels can be defined for each room based on gamma dose rate or activity in air levels, the acoustic and visual alarms being located local to the detector or relayed to a central area.

Our unique large area positron detectors are typically built into the ventilation ducts eliminating the requirement for offline sampling pumps ensuring maintenance free operation.

Stack emission of radioactivity is also possible using high efficiency positron sensitive detectors with a typical installation having a minimum detectable limit of 80 to 100 Bq/m³.

A number of data acquisition systems are available depending on the requirements of the facility. Berthold brings experience from more than 100 reference PET facility monitoring projects around the world.



Berthold engineer installing a stack monitor at a PET facility

Gamma Dose Rate Monitoring

- Installed Gamma dose rate room monitoring
- Hot Cell interlocking
- Cyclotron Vault interlocking

Activity in Air Monitoring for Rooms and Stack Emission

- Room air monitors optimised for positron emission detection for localisation of activity in air releases
- Monitors for stack release with highest sensitivity

Data Acquisition, Visualisation, Archiving & Reporting

- Centralised data station, PC or SCADA options
- Local and distributed alarm beacons
- Remote display of key data on touch screens

Installation, Calibration and service

- Full service support from factory trained engineers

QC Equipment

- Radio-HPLC detectors for QC
- NaI Gamma Spectroscopy system for QC

Contamination, Exit and Portable Dose Rate Monitors

- Portable Contamination Monitors
- Portable Gamma dose rate monitors
- Portable Neutron dose rate monitors
- Hand and Foot Monitors
- Exit Monitors



Gamma Dose Rate Monitoring

for room monitoring, hot cell interlocking and vault door interlock

Berthold offers a full range of compensated Gamma dose rate probes to provide monitoring from 50nSv/h up to 10³ Sv/h.

Wall or ceiling mounted GM probes are typically used for room area monitoring. For hot cells we offer both ion chambers for high dose rate applications and GM detectors as required. Special miniaturised versions of the GM detectors are available with separate electronics positioned outside the hot cells to prevent radiation damage and allow installation into confined spaces such as transfer cells.

Suitable electronics are provided to display the live dose rate values, and switch relays for alarms and interlock signals.

A full cyclotron vault door interlock system can be integrated with the radiation monitoring system to include measurement from the Gamma dose rate probe, round clearance system, Castell key system, beam interlock, Rf and magnet on and beam on with graphic status display on the PC. The system is fail safe providing interlocking in the event of power failure, high dose rate, probe failure or other system malfunction.

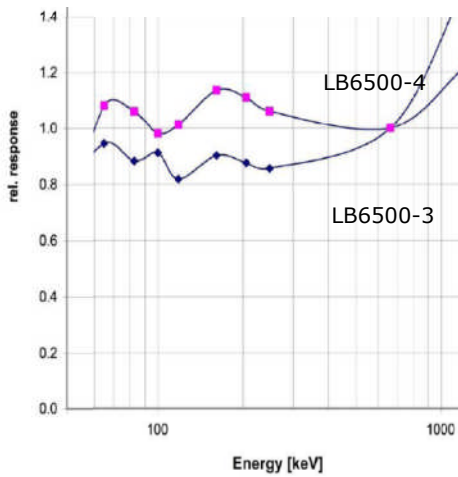

LB6500-4-H10 GM detector
100nSv/h to 10mSv/h, 65keV to 1.3MeV

LB6500-3-H10 GM detector
1uSv/h to 1Sv/h, 65keV to 1.3MeV

LB6701-H10 ion chamber
1mSv/h to 1000Sv/h, 45keV to 1.3MeV

PTB Type Tested



Hot cell & vault door interlocks, including fail safe interlock with automatic detection of probe failure.

Local display of dose rate values for each probe.

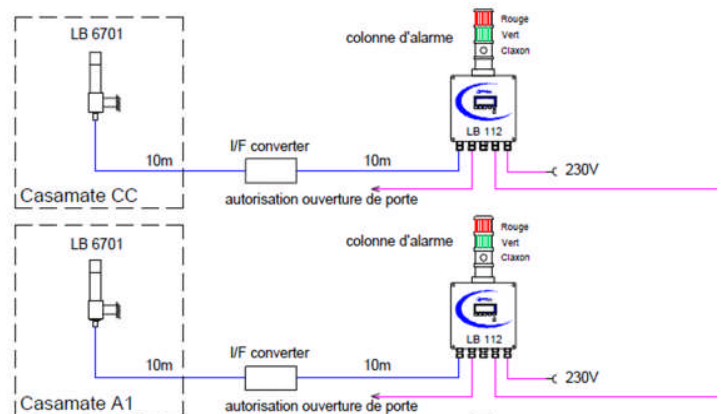
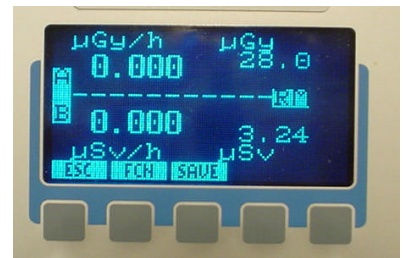

Activity in Air Monitoring for Rooms and Stack Emission

Berthold provides unique large area positron sensitive detectors with low sensitivity to ambient gamma radiation. The low gamma sensitivity and high positron efficiency allows any release of gaseous radioactivity to be instantly detected and localised within the facility.

In areas of very high ambient gamma backgrounds (for example in production areas handling several GBq of activity) detectors can be configured in anti-coincidence to eliminate the response to the 511keV emission resulting in a measurement of only the localised positrons in air.

The detectors are typically mounted within the ventilation ducts whose dimensions define the effective volume of the detector. The effective detector volume is therefore very large leading to extremely low detectable limits. A particular advantage of this arrangement is the elimination of sampling pumps which are required for off-line measurements. Sampling pumps require high maintenance and very secure sampling lines since any activity escaping from these lines may not be detected as the activity released will not reach the detectors.

For room monitoring large area rod detectors are flange mounted inside the ventilation ducts providing immediate alarms for localised activity in air releases.

1000cm² flat detector versions are used for the stack emission monitor to obtain minimum detection limits in the order of 80 to 100Bq/m³ which is unmatched by alternative detector technologies.

If the design of the ventilation system of the facility makes installation of in-line detectors impossible Berthold can provide off-line versions of these detectors but the recommended option is always in-line detectors.

LB6365 duct detector configuration for room air monitoring.

Detector volume example

These detectors are typically used to detect immediate accidental release of activity into a room (for example from a broken vial, target breakdown in the cyclotron vault or leak from hot cell)

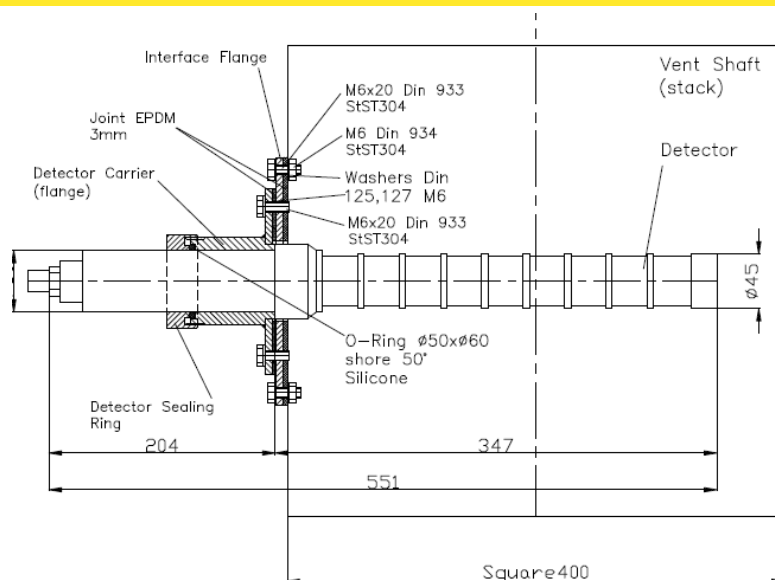

Typical mounting arrangement of the LB6365 in a 300mm diameter ventilation duct.

- High sensitive positron detector
- Large detector volume by using existing ventilation duct as integral part of the detector.
- No sampling pumps required, detector uses facilities normal ventilation system air flow
- Low maintenance as no sampling pump
- Teflon coated detector to eliminate plate out of FDG
- Low gamma sensitivity allowing localisation of air release in high ambient gamma areas
- Gamma compensation arrangements for exceptionally high ambient gamma areas (eg unshielded QC samples)

Activity Stack Emission

The Euratom recommendations 96/29 and 97/43 and ICRP60 have been adopted into local laws and regulations in each country. The requirement to monitor the total emission of radioactivity from a PET facility is dictated by the requirement to ensure the effective dose burden to the General Public remains below the specified level. For the UK IRR99 specified 1mSv/yr level whereas the German regulations specify 0.3mSv/yr (less than medium fluctuation due to natural Radon exposure of 2,4 mSv/Yr and below the EU basic standard of 1 mSv/Yr).

This translates into maximum release rates for different isotopes. Short lived isotopes have the highest permissible levels however the elimination rate from the lungs is also considered. For example in Germany the release of a F-18 compound with fast lung elimination would have a maximum limit of $4.5 \cdot 10^3$ Bq/m³ (F) compared to $2.1 \cdot 10^3$ Bq/m³ (S) when elimination is slow.

This consideration results in the Environmental Agency requiring facilities to monitor and record the amount of radioactive emissions from a facility and will indeed require the operator to obtain a licence for a specified release having a defined limit per day.

In order to comply with the regulations a stack emission detector is required with high sensitivity to enable accurate quantification of the activity released. An accurate measurement of the air flow in the stack is also required and is supplied as part of our system.

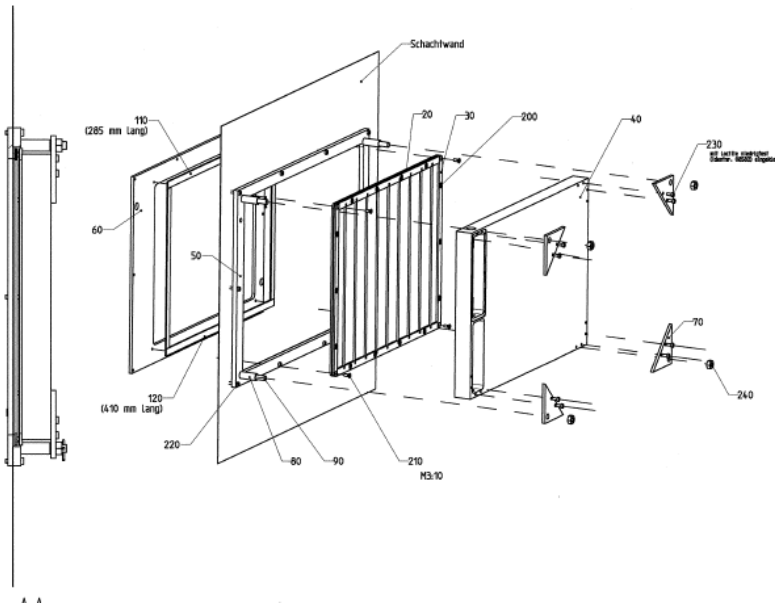

LB6377 Stack emission detector

- Large area (1000cm²) positron sensitive detectors, gamma insensitive.
- Detector response is independent of temperature between -15°C and +45°C.
- MDA typical <math><100\text{Bq/m}^3</math> for 800x300mm , effective detector volume stack, 1000s measuring interval.
- IP65 version available for mounting outside
- Maintenance free
- All stack release calculations are performed by the **LB5340** Data Logger



Flow Rate Measurement

Thermal anemometer

- Simple to install
- Virtually maintenance free
- Accuracy around 5%
- May not be representative for large ducts with turbulent flow

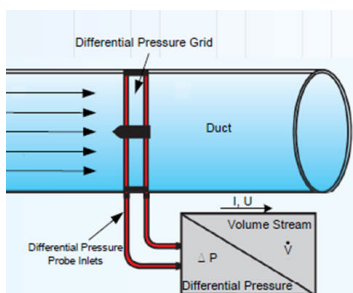

Wilson Grid

- Averages flow across whole cross section of duct
- Accuracy around 3%

Data Acquisition, Visualisation, Archiving and Reporting

A number of data acquisition, alarm and control systems are available depending on the requirements of each facility. The **LB112** can provide individual measuring stations for a pair of detectors with display of instantaneous radiation levels together with multiple local and/or alarm outputs. The alarm relays can also be used for hot cell interlock purposes.

A multichannel data logger, **LB9000** provides a central station connected to multiple probes within the facility. The multichannel system provides trend graphics for all of the connected probes together with daily release values from a stack detector. For smaller installations the 6 radiometric channel **LB5340** can be used.

For long term data archiving the above systems can be linked to the Windows based MEVIS PC software. MEVIS provides a full database of all the radiological measurements, historical and active alarms together with flexible reporting which is especially important for stack release data. Multiple systems can be linked via RS232/485 or Ethernet.

For an even greater degree of facility monitoring we offer a full System Control and Data Acquisition (SCADA) system. This system provides full data collection from all the measurement detectors and integrates other building signals such as cyclotron status, vault door interlocking, hot cell interlocks, ventilation status of each room/hot cell. Each room of the facility is graphically shown, together with the detector values and alarm status. A number of remote touch screen displays located throughout the building allows personnel to view activity levels and various building status signals from remote locations.



The **LB112** allows connection of two probes (for example LB6500 Dose rate probe and LB6535 Activity in Air probe) and provides a visual display of the live measurement.

The alarm beacon can be mounted on the enclosure, as shown, or remote as required.

A number of LB112s can be networked with a central archiving software (MEVIS or SCADA).

Multiple alarm relays are provided for each measuring channel allowing the unit to directly activate interlock signals.

The **LB9000** allows multiple detectors to be connected directly to a central location.

The system is modular allowing configuration for the required number of probes and alarm/interlock relays as the facility requires.

The built-in display allows graphic representation of the radiometric data.

Reports can be generated automatically such as daily stack release data.

For data archiving the system can be interfaced directly with MEVIS.

The LB9000 offers an intermediate solution to a full SCADA system.



Data Acquisition, Visualisation, Archiving and Reporting

MEVIS provides a Windows PC based software for visualisation of the radiological data in real time and from a historical database. Alarm status is also archived allowing a full history of the facility' status to be recalled.

A single page graphic of the building is provided with a summary overview of the dose rates and activity in air status for the facility. Individual detector time trend graphics are provided together with accumulated release values and air flow rates from the stack release monitor.

Alarms can be defined within MEVIS to alert the user of an accidental release of activity or if they are approaching the daily authorisation activity limit. Full reporting of the released activity is provided.

Berthold also offers a full System Control and Data Acquisition (SCADA) for PET facilities. By using a SCADA system Berthold can provide a fully integrated solution for radiation monitoring application.

The SCADA system allows multiple input and output signals to be combined with the radiological measurement data. All probes are directly connected to either one or multiple "Nodes" located in the building, the Nodes are then connected via Ethernet to a central SCADA PC running industry standard application software specifically configured for the application. Additional signals can be integrated with the measurement, such as the status of ventilation systems, cyclotron (Rf, beam on, magnet on), hot cell door interlock , vault door interlock. Having all this information correlated in a single database provides greater insight into the facility's operation.

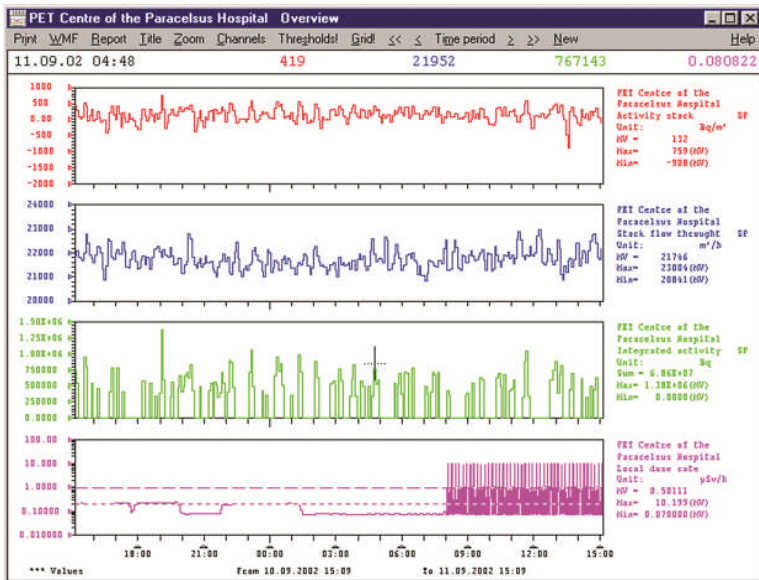

MEVIS Central station screen display of radiometric data from four probes within a PET facility.

Displays include building graphic summary, trend displays, alarm status (both live and historical), accumulated stack release activity as an amount and as a percentage of daily authorisation.

Alarms can be provided locally or at the central MEVIS station.

MEVIS can connect to multiple data loggers such as the LB112 and LB9000 and provides full archiving of the radiological measurements.

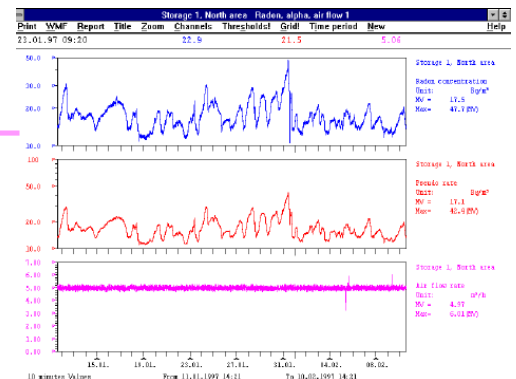

MEVIS Central Station

QC Equipment

Berthold offers two radio-HPLC detector models which can be used in the PET QC laboratory. Additionally a NaI Gamma Spectrometer is available to check for isotope purity.

The radio-HPLC detectors can be supplied with the Berthold *RadioStar* PC software or can be linked directly to the customers HPLC data station. The **LB2045** Gamma Spectroscopy system can be linked directly to a printer for hardcopy spectra and reports or connected to a PC spectroscopy software including data storage.



- **LB513** High sensitivity Radio-HPLC detector with coincidence counting and luminescence subtraction.
- Touch screen display for ease of operation
- Automatic cell identification
- Built in leak detection
- Integrated multi channel analyser
- Built in QC performance tests
- Available with Berthold *RadioStar* software or with external output to other HPLC software (eg Chromeleon)
- Unique flow cells optimised for PET isotopes with high positron efficiency and virtually no background from 511keV gamma

LB500 Radio-HPLC detector

- NaI detector version with lead shielding for all Gamma isotopes.
- Special PET version with unique positron sensitive flow cell/detector configuration which virtually eliminates background influence from 511keV gamma emission even without lead shielding.

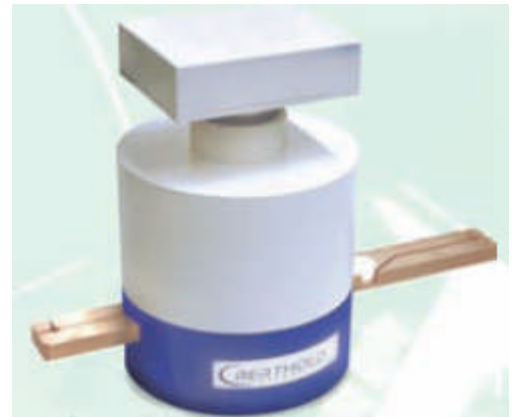

LB2045 Gamma Spectrometer

- NaI detector options include well crystal with lead shielding
- 1024 channel spectrum
- Touch screen display
- Printer option
- PC software option
- Peak integration and ROI reports
- Half-Life correction
- On board storage of spectra

Contamination, Exit and Portable Dose Rate Monitors

Berthold provides a full range of contamination and dose rate monitors ideally suited for the PET laboratory.

Contamination monitors can be mounted on wall brackets to provide a solution for exit monitoring or a dedicated Hand and Foot Monitor with personnel ID card reader option can be provided. Portable Gamma and Neutron dose rate monitors are available with the LB123 electronics shared between the different probes.



LB147 Hand and Foot Monitor

- Optional card reader for user ID with PC database software logging
- Card type matched to users existing door access card
- ZnS detector with high efficiency for PET isotopes
- Touch screen display for ease of operation
- Dynamic background subtraction for operation in fluctuating backgrounds
- Detachable frisker probe
- User defined thresholds in cps or Bq/cm²
- User can economically replace damaged detector foils

LB124SCINT Contamination Monitor

- Large area ZnS detector with high sensitivity
- Lightweight and easy to handle
- Reading in cps or Bq/cm²
- Calibration factors for all PET isotopes
- User can economically replace damaged detector foils
- Exit monitor option with wall bracket
- Larger probe (LB124Scint-300) option available, especially suited as an exit monitor



LB123 Universal Monitor

- Single electronic unit which can connect to multiple probe types
- 200cm² contamination probe as exit monitor
- Neutron probe
- Gamma Dose rate and Integrated Dose probe