

# Characterization of Large Structures & Components

### Key Drivers:

- Lack of good knowledge about the position, the identification and the radiological specification of contamination on or inside large components.
- Significant high global background, within relatively medium activities of components.
- The identification and estimation of the activity become complex in hot cells, where space is limited and human intervention difficult as per ALARA principles.
- Achieve accurate measurements, but also activities per radionuclide, and localization of hot spots.



### KEY BENEFITS

- ➔ Control cost and risks of the total project
- ➔ Source-Less calibration with the ISOCS™ system
- ➔ Optimized Waste Segregation

### Objectives:

- Identify the activity of hot spots or contaminated surface using gamma imaging and spectroscopy.
- Perform mobile real-time position measurement.
- Modeling of many types of contaminated surfaces or components.
- Immediate, easy and accurate source-less calibration measurements.
- Reduce costs, time and risks of measurement.
- Release of structures and components materials without cutting them.

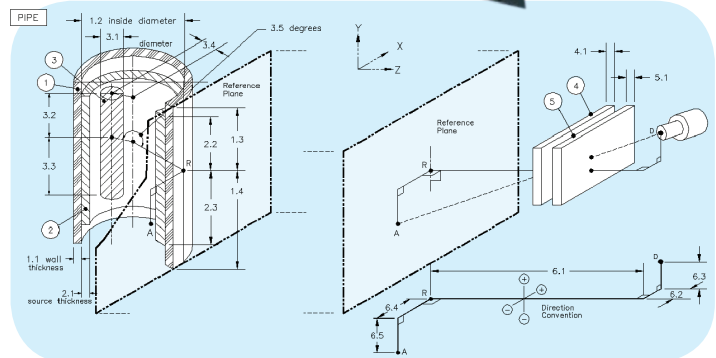
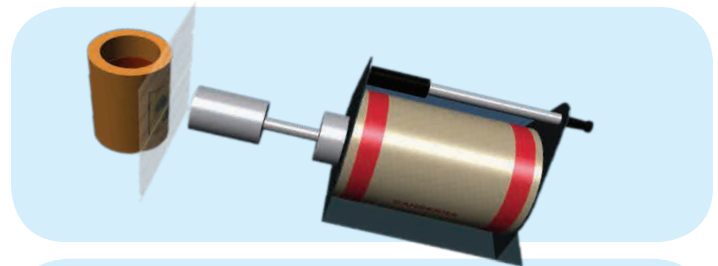

# Characterization of Large Structures & Components

## D&D Capabilities and Solutions

### iPIX Gamma Imager: Real-time Monitoring & Hot Spots Localization

iPIX is a unique gamma imager that quickly locates low level radioactive sources from a distance while estimating the dose rate at the measurement point in real time. It is the ideal tool to map a radioactive area before entering the zone, thus reducing the dose exposure (ALARA) for the workers.

Due to the use of the coded masks, the need for heavy shielding has been eliminated, making it a compact and lightweight (~2.5 kg) system.

- iPIX is an excellent tool to precisely locate the radioactive source position. Knowing the position helps to improve the activity calculation correctly when using the ISOCS system.
  - Best tool to track low energy emitters.
  - Industrial design for use in harsh environments (IP65).
  - Can be operated remotely minimizing exposure to the operators (ALARA).
  - User friendly, with push button image acquisition.
  - High performance to quickly and precisely locate hot spots.
  - Estimates dose rate at the measurement point.

iPIX allows localization of radioactive sources in many kind of nuclear plant components, building, pipes, drums, scraps, etc...

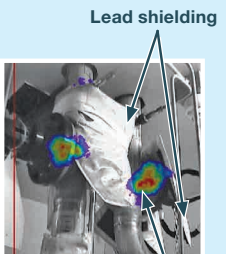

Lightweight unit can be deployed and transported in the field



NPP Example – Setup and Control of Radiobiological Protection

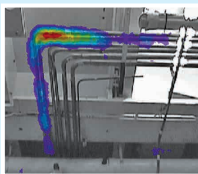

Pipelines



Unshielded transport container

### ISOCS System Measurement

- The In Situ Object Counting Systems (ISOCS) is commonly used to measure contaminated materials and areas, both in place or after removal from the facilities, also for final status measurement to the clearance.
- HPGe detectors have the best FWHM resolution in gamma spectroscopy and allow fastest specific nuclide identification, even with complex spectra. NaI detectors have a good efficiency for very low activity determination of simple nuclide mixes. CZT detectors are small but have a better energy resolution than NaI detectors.

#### Key benefits

- Immediate, accurate, nuclide-specific results for in-situ measurements of any object or surface.
- Source-Less detector-specific calibrations generated by software as the sample is being calibrated.
- All calibrated objects/surface are usually plane, cylinder, box, sphere, well/Marinelli or pipe.
- Mobile detector positioning device includes 25 mm, 50 mm collimators (for HPGe detectors) and backshields. It accommodates any detector orientation. Custom-designed collimators can also be used.
- Complex pipe template allows modeling of complex, multi-layer pipes and drums.
- Allows modeling of In depth profile contamination.
- Wide range of detectors (HPGe, NaI, CZT, LaBr) compatible, allowing operation for range of applications and activities.
- Use of Advanced In-situ Gamma Spectrometry (AIGS) Services to optimize waste segregation by improving assay accuracy (for example when activity is inhomogeneous).

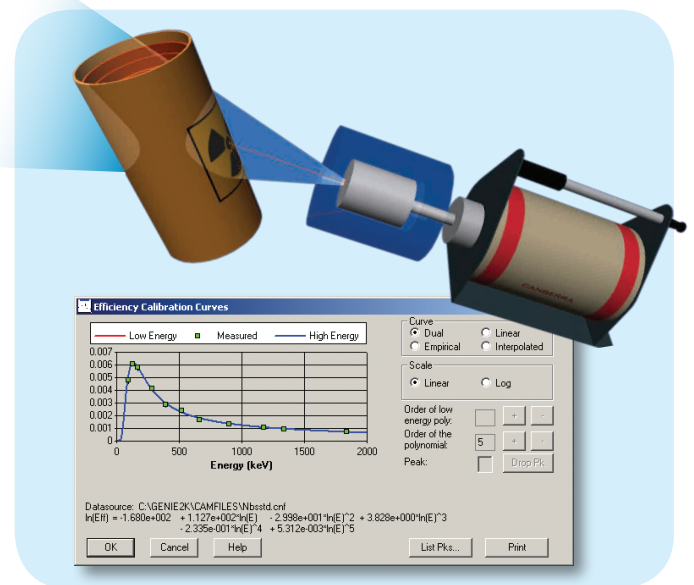

# Characterization of Large Structures & Components

## D&D Capabilities and Solutions

### Dose rate measurement + mapping

Mirion offers dose rate meters for a wide range of users and probes to suit many applications.

All CANBERRA™ Smart Probes can be plugged to the Mirion family of Smart survey meters. A GPS survey meter is available to identify the position of measurements and give a real time measurement of dose rate and gamma spectra simultaneously.

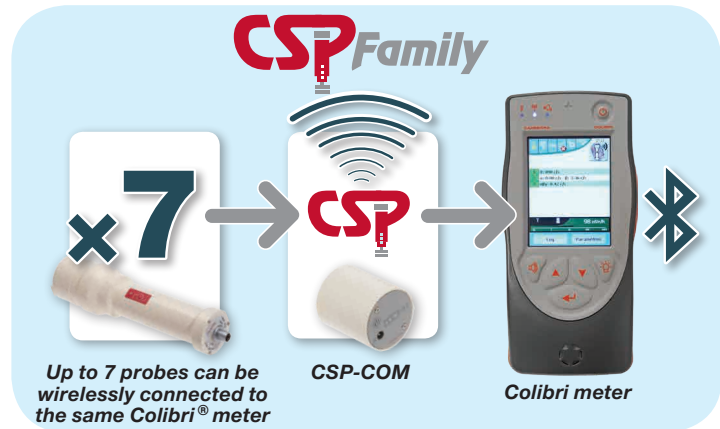

A COLIBRI Communication ALARA Platform

LynxNavi is a software developed for supporting all acquisition modes proposed by the Mirion high performance multi-channel analyzers (MCA) using NaI to obtain gamma spectra and with high performance analysis.



LynxNavi used with the Osprey® MCA

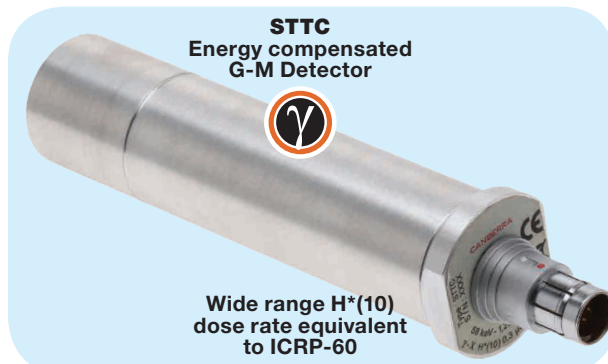

Uses our unique "Time-to-Count" technique with many of its Geiger Mueller detectors

Many Mirion detectors are appropriate for different levels of dose rate measurement, giving 3D mapping of dose rate and gamma energy on a large surface. The Colibri instrument is equipped with a GPS system, giving an accurate mapping of a large surface.

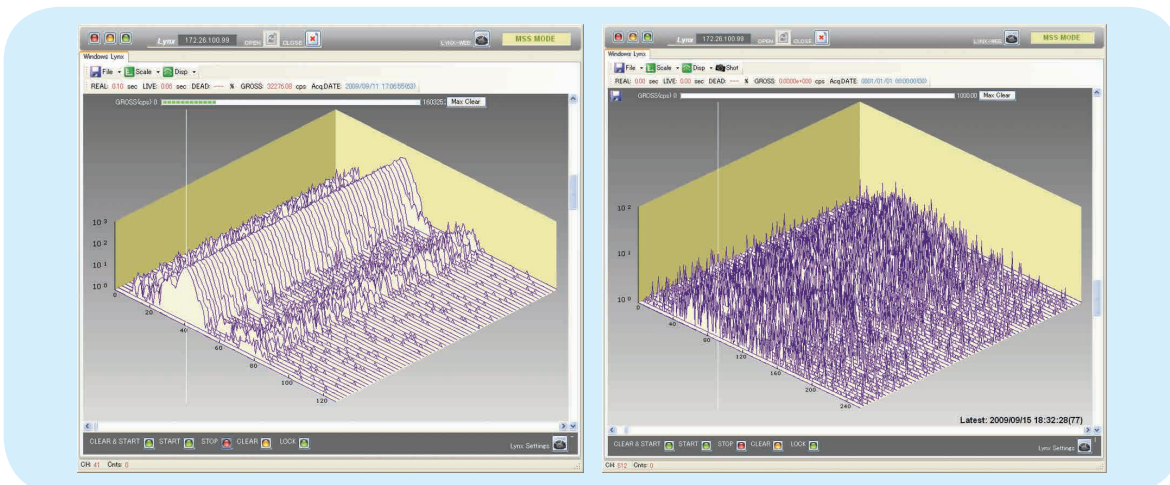

### Plant components contamination

#### Object internal surface contamination by simulation: dose rate probe + ISOCS + MERCURAD® + MCNP® codes

#### Objectives:

- Characterization of high dose rate contaminated surface (on the pipes, tanks, walls, etc...) in limited access areas inside a plant.
- Characterization of waste level of components to define the best dismantling scenarios and safety analysis.

#### Method:

##### Step 1

- Assessment of the status of the areas or objects. Review the plant's operational history. Evaluate where the potential contamination areas or hot-spots are located.

##### Step 2

- After evaluation of the dose rate, depending on accessibility, drill holes or directly use the suitable detectors (GM, CZT, etc...) in different positions, thus accurately obtain the dose rate.

##### Step 3

- iPIX deployment to locate the positions of hot spots.

##### Step 4

- Simulation of the whole detection system and the components or areas using the ISOCS system or the MERCURAD\* software and MCNP software, insert the dose measurement data to evaluate the activity of the contaminated hot-spots.

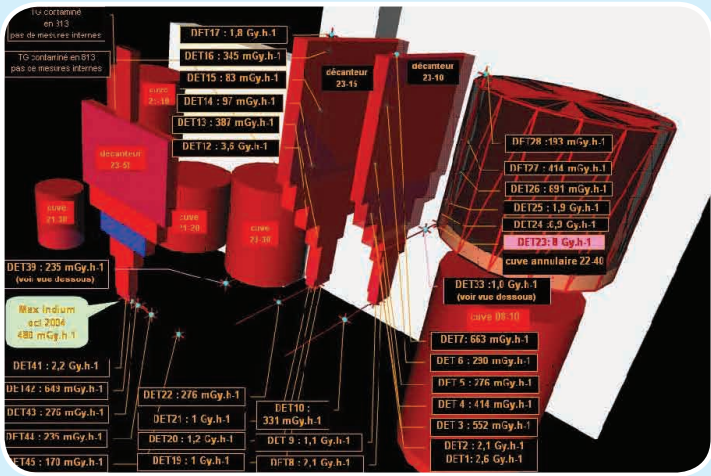

The image shows a 3D simulation of the La Hague reprocessing plant. It features several cylindrical tanks and complex piping structures. Numerous data points are overlaid on the simulation, each representing a detector location and its measured dose rate. The dose rates range from 1.0 Gy.h<sup>-1</sup> to 331 mGy.h<sup>-1</sup>. A specific callout for 'Max Indium sci 2004' shows a value of 480 mGy.h<sup>-1</sup>. The simulation is presented in a perspective view, with some components highlighted in red.

#### Case study: La Hague reprocessing plant

This project covered a very large range of dose rates from 100 nGy/h to 100 Gy/h. To reduce cost, save time, minimize dose and avoid opening hot cells and cutting tanks, systems at La Hague reprocessing plant were evaluated by simulation code to determine the positions of contaminated areas.

The objective of this project was totally achieved. We proved that more than 50% of the tanks could be considered as very low level waste. It drastically changed the previously envisaged decontaminating and dismantling process.

\* **The MERCURAD software**, offers a practical solution to meet the complex dose calculation requirements of health physics specialists, shielding calculation engineers, and staff involved with nuclear facility maintenance and nuclear installation dismantling projects.

### Surface contamination

#### Activity measurement:

##### Method

- Locate the contaminated source (using gamma imaging system and/or Geiger Mueller detectors).
- Use spectrometer (HPGe, CZT, NaI or LaBr, etc.) to obtain gamma spectrum of the hot spot(s).
- Use an ISOCS template to obtain the geometry detection efficiency (Gamma attenuation calculation code).
- The gamma spectrum will be analyzed using spectroscopy code (Genie™ 2000 software), combining the detection efficiency from the ISOCS template and eventually deducing the activities of the contamination/source(s).
- Advanced In-situ Gamma Spectrometry (AIGS) Services can greatly improve the accuracy of activity results based from the ISOCS system.

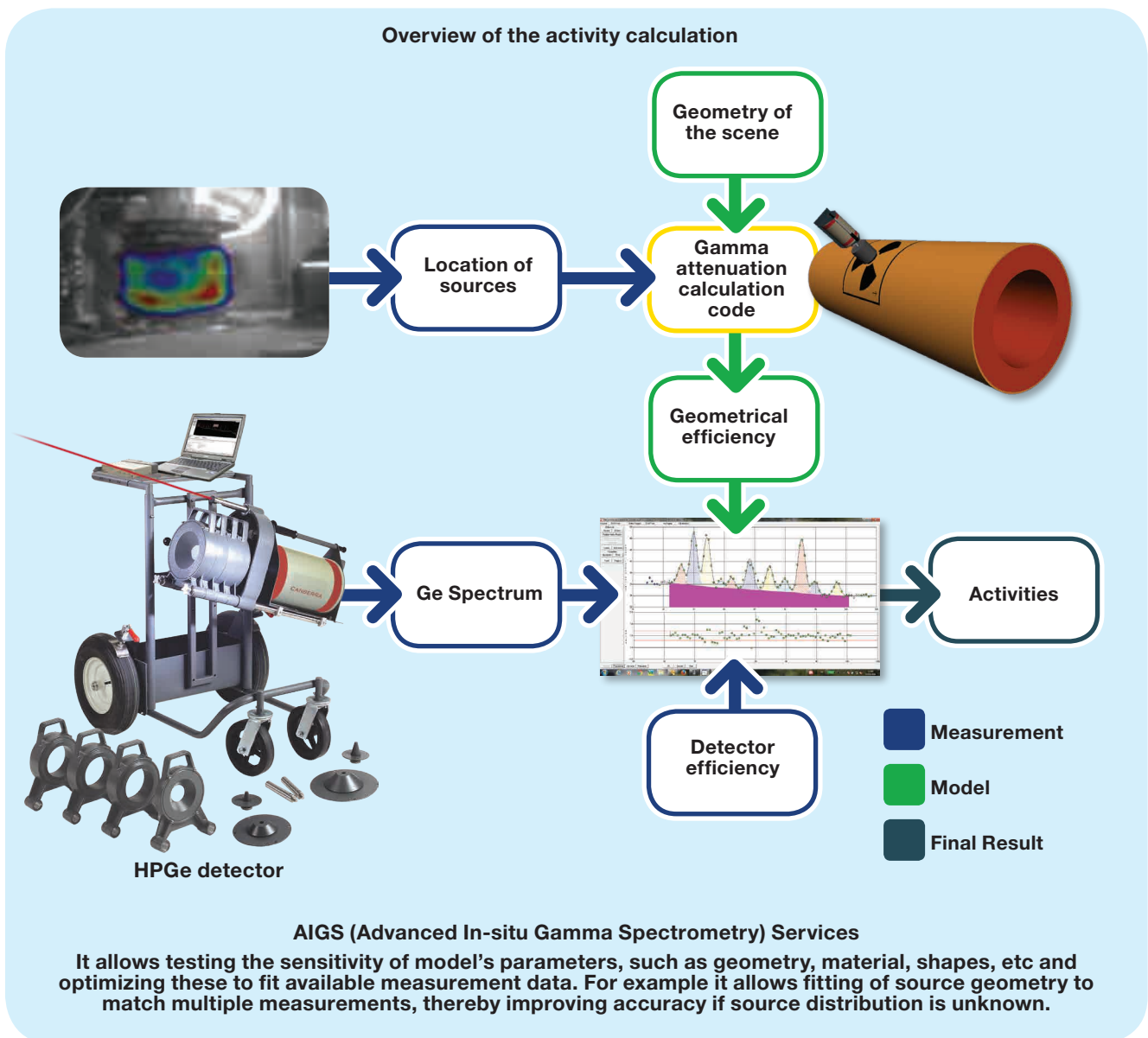

### Surface contamination

#### Case Study: Bulk Waste Characterization with ISOCS, and Verification with samples having well-known activities

- **Figure 1** shows the measurement of contaminated soil from a shutdown nuclear power plant. A container full of soil sample was measured using a HPGe detector which was inserted inside a lead collimator.
- The detector efficiency was calculated with an ISOCS template as shown in **Figure 2**.
- The ISOCS in-situ measurement of this sample was obtained, and compared to the sample dose rate as shown in the **Figure 3**. The blue points represent the ratio between the two values, and the data match very well.



Figure 1

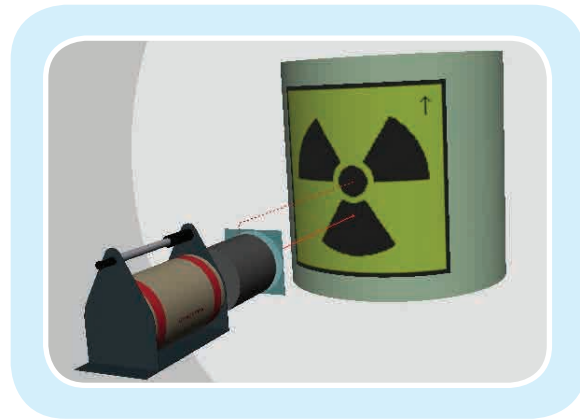

Figure 2

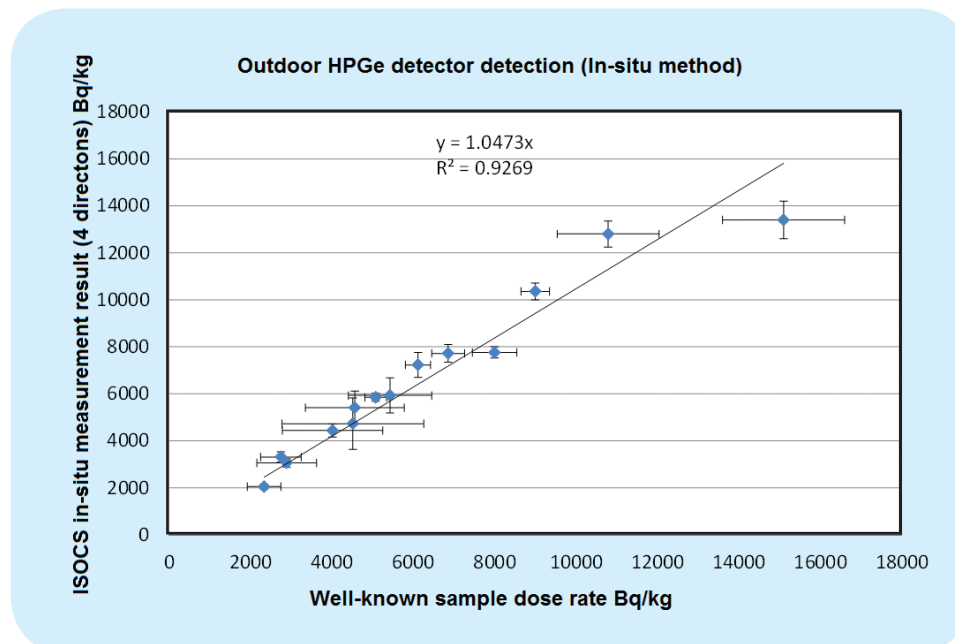

Figure 3

# Characterization of Large Structures & Components

## D&D Capabilities and Solutions

### Plant components contamination

Mirion has the expertise to successfully characterize large surfaces and plant components. These projects have been achieved leading to costs and time reductions for customers.



Characterization of heat exchangers for free release at Seabrook NPP (USA).



Using the ISOCS system to characterize a crane in nuclear plant in US, demonstrating the capability to characterize massive objects.

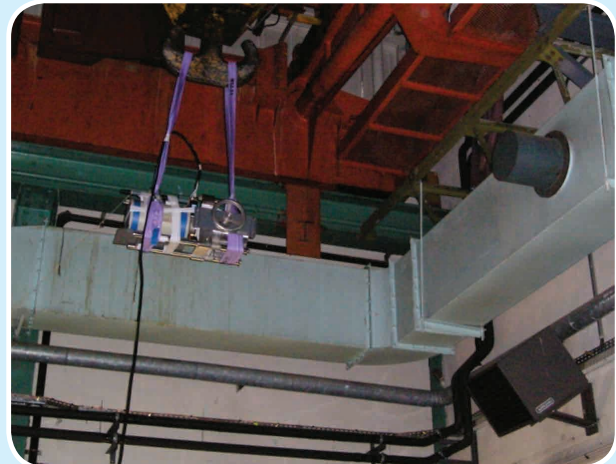

Characterization of pipes and tubes in nuclear plant components.

# Characterization of Large Structures & Components

D&D Capabilities and Solutions

## Successful achievements

Characterization of different small irregular objects using the ISOCS system.

We successfully characterized a large area full of metal scrap piles with steel tubes using the ISOCS system.



Copyright ©2018 Mirion Technologies, Inc. or its affiliates. All rights reserved. Mirion, the Mirion logo, CANBERRA, ISCOS, Colibri, Osprey, Mercurad, Genie and other trade names of Mirion products listed herein are trademarks and/or registered trademarks of Mirion Technologies, Inc. and/or its affiliates in the United States and/or other countries. MCNP is a trademark and/or registered trademark of Los Alamos National Security, LLC. Third party trademarks mentioned are the property of their respective owners.



For more information, review the complete case study on our website:  
[www.canberra.com/measurements-expertise](http://www.canberra.com/measurements-expertise)

- Characterization of Rocky Flats Environmental Technology Site through paint Sampling and rapid gamma Spectroscopy. (C40863)
- Decommissioning of a medical cyclotron using ISOCS. (C48088)
- Large Area mapping using ISOCS and Geostatistics. (C48136)
- ORCADE-DV D&D Project in La Hague Reprocessing Plant, France (\*C48360)

Radiation Safety. **Amplified.**  [www.canberra.com](http://www.canberra.com)

**CANBERRA**  
Part of Mirion Technologies

C49116 – 06/2016